

YSHL

초고속 중공슬림형 실린더 (롱스트로크)

SUPER HIGH SPEED BIG BORE HYDRAULIC(Long Stroke)

超高速中空スリム型シリンダー / 超大通孔油缸

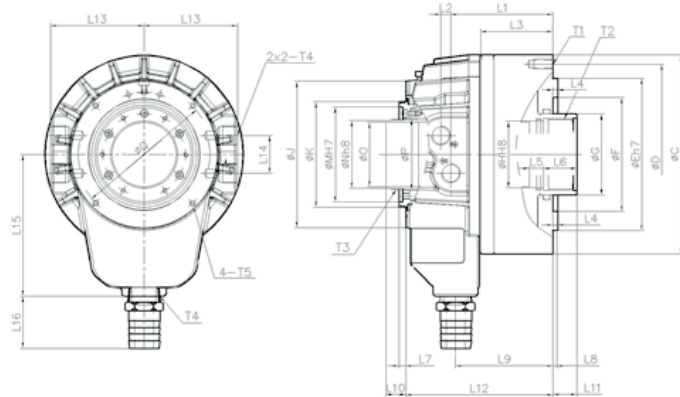

- 호환성 실현 • 소형화 경량화 • 안전 확보 • 누유방지 설계(특허등록:0172805) • 동급 최대 추력
- Compatibility • Small Size & Light Weight • Safety Guaranteed • Leakage Prevention Design • Highest Draw Pull
- 互換性実現 • 小型化, 軽量化 • 安全確保 • 漏油防止設計(特許登録) • 同クラス最大推力
- 实现兼容性 • 体积小, 重量轻 • 保障安全 • 防泄漏设计(专利注册:0172805) • 动力强大

※ 허용 최고 회전속도는 실측치에 준함.
 ※ Maximum turning speed is based on actual measurement.

Specifications / 规格 / 仕様表 / 사양표

Spec.사양 Mode형식	Order NO. 오더번호	Cylinder Dia 실린더내경 mm	Piston stroke 피스톤스트로크 mm	Thru hole Dia 실린더관 통경 mm	Piston surface area 피스톤 단면적 cm ²		Max. Draw bar pull 실린더 추력 KN(kgf)	
					Push 압축	Pull 인축	Push 압축	Pull 인축
YSHL-15	2SHL15	250	50	117.5	364.4	331.8	129.8(13233)	118.2(12050)
YSHL-21	2SHL21	280	51	166.5	372.1	327.1	111.5(11376)	98(10002)
YSHL-32	2SHL32	390	51	240	683	643	101.4(10245)	95.4(9645)

Spec.사양 Mode형식	Max. operating pressure 최고사용유압력 kgf/cm ²	Max. permissible speed 최고사용회전수 r.p.m.(min ⁻¹)	Total leakage 총드레인량 ℓ/min	Weight 중량 kg	GD ² Moment of inertia N·m ² (kgf·m ²)	Matching chuck 적용척
YSHL-15	408	3000	7	52	186(1.9)	CAH-15, 18, 24
YSHL-21	336	2000	8.4	77	294.3(3)	CAH-21, 24
YSHL-32	25	1500	18	135	392(4)	CAH-32

Dimension / 尺寸 / 寸法表 / 치수표

Item항목 Mode형식	C	D	E	F	G	H	J	K	M	N	O	P	Q
YSHL-15	307	275	230	170	140	123	216	167	152	122	117.5	175	256
YSHL-21	354	290	260	240	190	170	278	217	205	170.5	166.5	175	256
YSHL-32	454	420	320	280	265	243	358	297	285	250.5	240	255	330

Item항목 Mode형식	L1	L2	L3	L4	L5	L6	L7	L8	L9	L10 max	L10 min	L11 max	L11 min
YSHL-15	168.5	185	129	6	20	45	9.85	6	190	76	26	46	-4
YSHL-21	182.5	185	139	7	20	45	9.85	5	200	76.3	25.3	51	0
YSHL-32	186	185	138	5	20	45	9.85	5	213	76	25	50	-1

Item항목 Mode형식	L12	L13	L14	L15	L16	T1	T2	T3	T4	T5
YSHL-15	241	140	40	215	50	12-M16X32	M124XP2.0	M111XP2.0	PT-1/2	4-M6X10
YSHL-21	259.5	172.6	40	255	55	12-M16X32	M180XP3.0	M173XP2.0	PT-1/2	4-M6X10
YSHL-32	277	214	40	332	58	12-M16X40	M250XP3.0	M253XP2.0	PT-1/2	6-M6X15

※ 치수 및 사양은 예고없이 변경될 수 있습니다.
 ※ Specifications are subject to change without notice.