

SYH 标准中空液压缸



产品特点

轻量缩短大口径超高速中空液压缸

主要技术

内置 Lock Valve, Relief Valve, 防过压, 预防液压缸受损, 停电或压力急降时保持推力

产品规格

	SYH-1036	SYH-1246	SYH-1552	SYH-1877	SYH-2091
通径 [mm]	36	36,39,40,41,43,45,46	46,52,69	68,69,75,77	78,91
活塞直径 [mm]	105	125	155	180	205
活塞行程 [mm]	15	15	22	25	30
活塞面积 (Push) [cm ²]	67	100	161	198	252
活塞面积 (Pull) [cm ²]	64.5	89	150	183	234
Piston Force (Push) Push [kN(kgf)]	25(2549)	38(3875)	60(6118)	74(7546)	94(9584)
Piston Force (Pull) Push [kN(kgf)]	24(2447)	33(3365)	56(5710)	69(7036)	88(8973)
最大工作压力 [MPa(kgf/cm ²)]	4.0(40.8)	4.0(40.8)	4.0(40.8)	4.0(40.8)	4.0(40.8)
允许的最大最大转速 [min ⁻¹]	8000	8000	6200	4700	3800
惯性力矩 [N · m ² (kg · m ²)]	0.10(0.011)	0.18(0.019)	0.52(0.053)	0.93(0.095)	1.45(0.153)
重量 [kg]	8.6	12	16.8	26	33
总 Leak 量 [ℓ/min]	3	3	3.9	4.2	4.5
KITAGAWA® Model	S-1036	S-1246	S-1552	S-1875	S-2091

※ 允许的最大转速以实测值为准。
 ※ 尺寸与规格可能不事先预告即作变更。

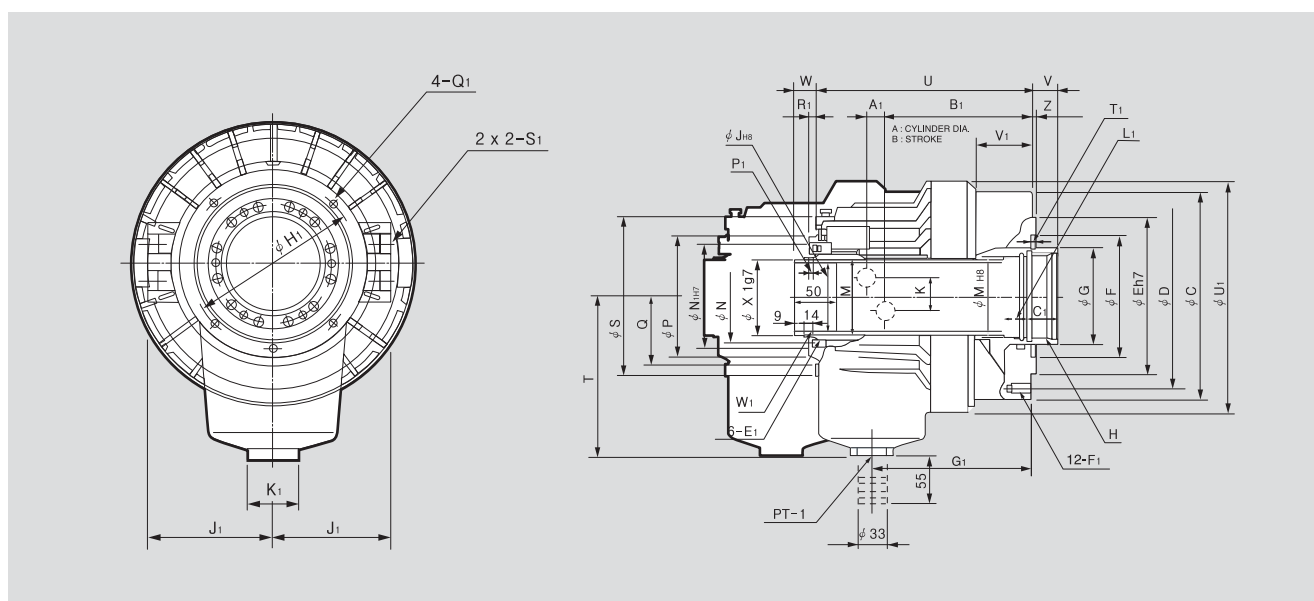

※ 参照右侧各产品尺寸

产品尺寸

	SYH-1036	SYH-1246	SYH-1552	SYH-1877	SYH-2091
ΦC	135	155	190	215	240
ΦD	115	130	170	190	215
ΦE	100	100	130	160	180
ΦF	65	80	85	120	140
ΦG	48	65	70	95	110
H max.	M42x1.5	M52x2.0	M60x2.0	M85x2.0	M100x2.0
ΦJ	36	46	52	77	91
K	30	36	36	36	34
ΦM	44.6	52.9	59.6	84.6	99.6
ΦN	55	64	73	98	108
ΦP	73	85	96	121	138
ΦQ	45	51.5	57	70	79
ΦS	104	118	137	166	182
T	115	115	130	160	185
U	156	184	191	230	253
V max.	15	15	22	25	30
V min.	0	0	0	0	0
W max.	40	40	47	50	55
W min.	25	25	25	25	25
Z	5	5	5	5	5
A1	11	11.5	12	17.5	21
B1	102.5	126.5	136	153.5	168
C1	25	30	30	35	35
E1	M5x11	M6x9	M6x9	M6x9	M6x14
F1	6-M10x17	12-M10x20	12-M10x20	12-M10x20	12-M12x24
G1	98	135	145	166.5	183
H1	88	98	110	155	165
J1	73	76	86	101	110
K1	47	47	47	47	47
L1	15	15	15	15	15
M1	38	50	55	80	95
ΦN1	64	76	85	108	120
P1	4	4	4	4	4
Q1	M5x10	M5x10	M6x12	M6x12	M6x12
R1	5	6	7	7	7
S1	PT3/8	PT1/2	PT1/2	PT1/2	PT1/2
T1	6	6	6	6	6
ΦU1	158	200	220	242	267
V1	28	46	51	58	66
W1	M44x1.5	M52x1.5	M58x1.5	M84x2.0	M99x2.0
ΦX1	42	50	56	81	96