

HYDRAULIC CYLINDER COOLANT COLLECTOR

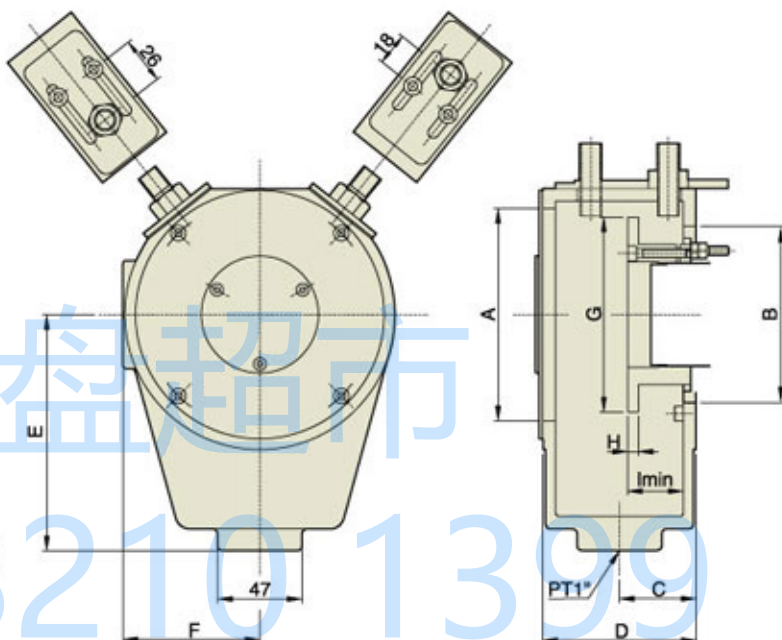
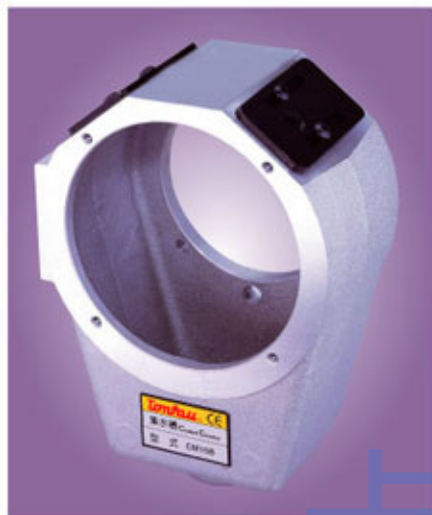

- 可安裝行程確認裝置及油水回收。
- Hydraulic cylinder coolant collector. Compact and light weight, the feature is the bore size up to 20% larger than conventional cylinders. Precision finished piston bores and cool running rotary unions have trouble-free performance for years.

尺寸表 DIMENSIONS

型式 Model	尺寸 DIM	A	B	C	D	E	F	G	H	Imin	適合油壓缸 Matching cylinder
CM08B		78	61	42	84	115	60.5	90	6	22	RC-4
CM10B		78	75	42	84	115	60.5	90	6	22	RC-5
CM12B		118	87	42	88.5	131	76	107	6	23	RC-6
CM15B		158	98	44	88.5	151	96	147	6	23	RC-8
CM18B		158	123	44	88.5	151	96	147	6	23	RC-10
CM20B		158	140	44	88.5	151	96	147	6	22.5	RC-12
CM25B		198	180	44	105	215	126	200	6	25	RC-15