

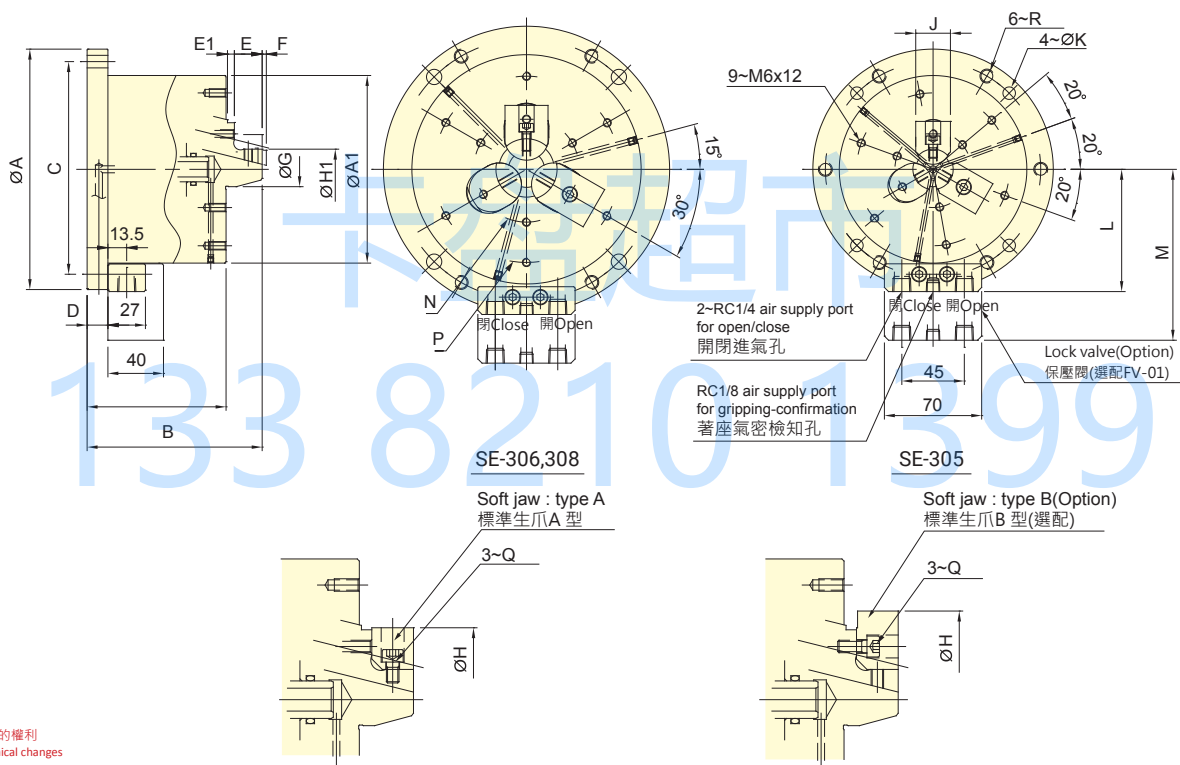

- 內建油壓缸，當使用氣壓做為動力源時，可選配保壓閥組件。
- 適用於內徑夾持
- 高精度安定性，適合最後製程加工。
- 可與立置夾頭座板組合進行加工。
- Build-in hydraulic cylinder; it can also work with lock valve and be driven by air pressure.
- For internal gripping
- With high precision and stability.
- Suitable for the precision large length size process.
- Suitable for end process.
- Can work together with multi-plate.
- 氣密檢知 (選配)。
- Air-tight pressure detect function is optional.



保留規格修改的權利
Subject to technical changes

技術規格 SPECIFICATIONS

型號	爪行程 (直徑)	夾持直徑		最大夾持力		最大使用壓力		最低使用壓力	空氣消耗量	重量
		最大	最小	氣壓	油壓	氣壓	油壓		使用壓力 6.0 kgf/cm ²	
Model	Jaw stroke (Dia.)	Chucking Dia.		Max. clamping force		Max. pressure		Min. pressure	Air consumption	Weight
		Max.	Min.	Pneumatic	Hydraulic	Pneumatic	Hydraulic			
	mm	mm	mm	kN(kgf)	kN(kgf)	MPa(kgf/cm ²)	MPa(kgf/cm ²)	kgf/cm ²	lit (at 6.0 kgf/cm ²)	kg
SE-305	3	83	29	14.3(1459)	41.0(4181)	0.7(7)	1.3(13)	2	0.46	14.6
SE-306	5	110	44	20.0(2040)	57.0(5812)	0.7(7)	1.3(13)	2	0.58	20
SE-308	5	150	50	32.0(3263)	78.0(7954)	0.7(7)	1.3(13)	2	1.02	33

外型尺寸 DIMENSIONS

Model	A(h7)	A1	B	B1	C	D	E	E1	F max.	F min.	G	type A		type B	
												H max.	H min.	H max.	H min.
SE-305	173	135	126	100	155	15	20	5	3	-3	25	68	50	83	67
SE-306	206	168	140	108	188	18	23	7	5	-5	40	90	70	110	89
SE-308	248	210	164	119	230	18	30	9	5	-5	49	110	90	150	108

Model	H1		J	K	L	M	N	P	Q	R
	max.	min.								
SE-305	50	29	25	9	88	123	55	110	3~M6	M8x1.25
SE-306	70	44	31	11	104.5	139.5	76	134	3~M6	M10x1.5
SE-308	90	50	35	11	125.5	160.5	100	170	3~M8	M10x1.5