

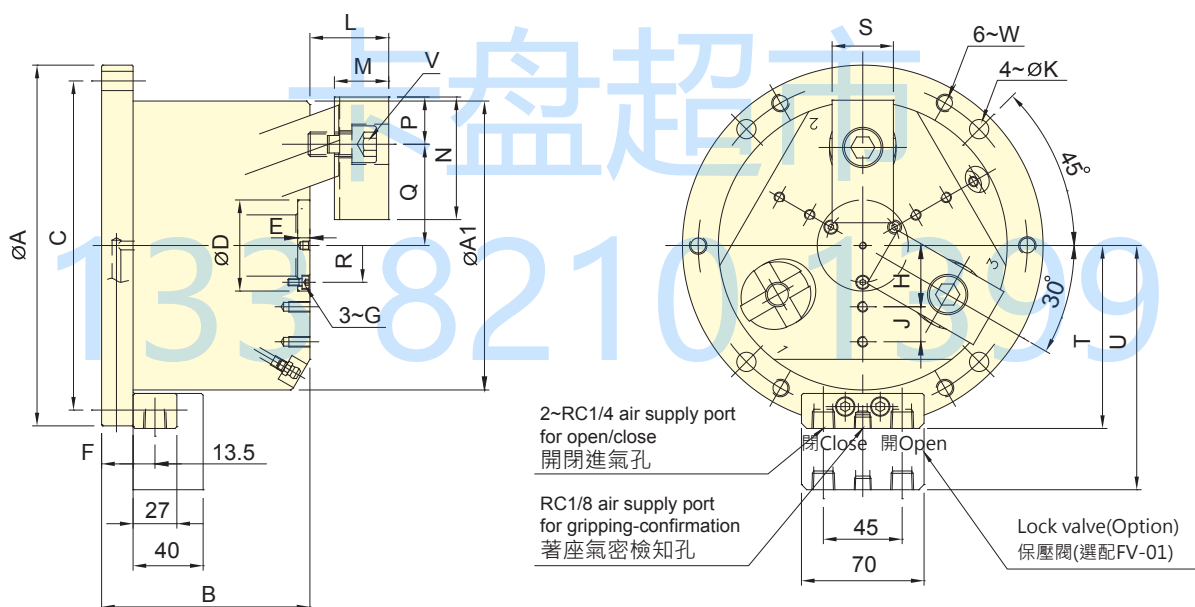

- 內建油壓缸，當使用氣壓做為動力源時，可選配保壓閥組件。
- 可同時將工件做徑向夾持與軸向後拉，使工件不上浮並緊貼座金基準面。
- 高剛性硬化處理的本體與圓柱後拉機構，並經過軸孔精磨，確保高夾持精度與耐用度，適合重切削場合。
- 可與立置夾頭座板組合進行加工。
- Build-in hydraulic cylinder; it can also work with lock valve and be driven by air pressure.
- Radial clamp and axial pull down at the same time, keep the workpiece attaching close to the base surface of the chuck.
- Almost no workpiece uplifting displacement.
- The body with heat treatment and the organization of cylinder pull-down and fine boring, which guarantee to the high clamping precision and durability, it's suitable for heavy duty machining.
- Can work together with multi-plate.
- 氣密檢知 (選配)。
- Air-tight pressure detect function is optional.



保留規格修改的權利
Subject to technical changes

技術規格 SPECIFICATIONS

型號	爪行程 (直徑)	夾持直徑		最大夾持力		最大使用壓力		最低使用壓力	空氣消耗量 使用壓力 6.0 kgf/cm ²	重量
		最大	最小	氣壓	油壓	氣壓	油壓			
		Max.	Min.	Pneumatic	Hydraulic	Pneumatic	Hydraulic			
Model	Jaw stroke (Dia.)	mm	mm	kN(kgf)	kN(kgf)	MPa(kgf/cm ²)	MPa(kgf/cm ²)	kgf/cm ²	lit (at 6.0 kgf/cm ²)	kg
SD-304	5	110	18	5.0(510)	10.9(1112)	0.6(6)	1.3(13)	2	0.26	8.1
SD-306	7.2	165	35	11.5(1173)	25.0(2550)	0.6(6)	1.3(13)	2	0.58	20.6
SD-308	7.2	210	28	21.7(2213)	47.0(4793)	0.6(6)	1.3(13)	2	1.02	34.1

外型尺寸 DIMENSIONS

Model	A(h7)	A1	B	C	D(H7/h7)	E	F	G	H	J	K	L max.	L min.
SD-304	148	110	93.5	130	35	2	15	M3	22.5	10	9	30	23
SD-306	206	165	116	188	52	7	18	M4	35	20	11	45	35
SD-308	248	210	122	230	65	10	18	M5	45	25	11	56	46

Model	M	N	P	Q max.	Q min.	R	S	T	U	V	W
SD-304	19.5	52	19	37	34.5	27	25	75.5	110.5	3~M10	M8x1.25
SD-306	31	70	27	57.8	54.2	42	35	104.5	139.5	3~M14	M10x1.5
SD-308	41	84	31	70.8	67.2	53	40	125.5	160.5	6~M12	M10x1.5