

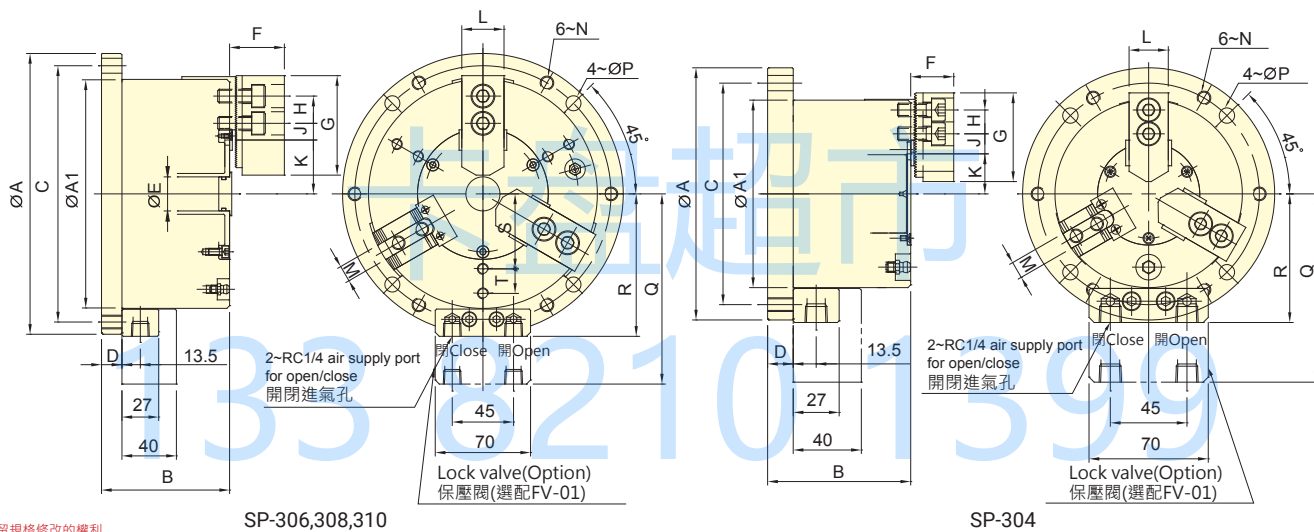

- 內建油壓缸。當使用氣壓做為動力源時，可選配保壓閥組件。
- 小的通孔徑，適合較長的棒材加工。
- 安裝容易，接上配管即可進行加工。
- 薄型輕量化設計，並可使用標準生爪或標準硬爪。
- 可與立置夾頭座板組合進行加工。
- Build-in hydraulic cylinder; it can also work with lock valve and be driven by air pressure.
- With small thru-hole and suits for long bar workpiece processing.
- Easy to install. Installing the tubes and then operating.
- Thin and compact design. Use standard soft jaws or standard hard jaws.
- Can work together with multi-plate.



保留規格修改的權利  
Subject to technical changes

### 技術規格 SPECIFICATIONS

型號	爪行程 (直徑)	夾持直徑		最大夾持力		最大使用壓力		最低使用壓力	空氣消耗量 使用壓力 6.0 kgf/cm <sup>2</sup>	重量
		最大	最小	氣壓	油壓	氣壓	油壓			
		Max.	Min.	Pneumatic	Hydraulic	Pneumatic	Hydraulic			
Model	Jaw stroke (Dia.)	Chucking Dia.		Max. clamping force		Max. pressure		Min. pressure	Air consumption	Weight
	mm	mm	mm	kN(kgf)	kN(kgf)	MPa(kgf/cm <sup>2</sup> )	MPa(kgf/cm <sup>2</sup> )	kgf/cm <sup>2</sup>	lit (at 6.0 kgf/cm <sup>2</sup> )	kg
SP-304	5.1	110	10	7.5(765)	22.0(2243)	0.6(6)	1.3(13)	2	0.5	7
SP-306	5.5	168	30	21.0(2142)	52.0(5303)	0.6(6)	1.3(13)	2	1.4	16.5
SP-308	6.8	210	42	33.0(3365)	74.0(7546)	0.6(6)	1.3(13)	2	2.5	28.7
SP-310	7	254	52	48.0(4895)	107.0(10911)	0.6(6)	1.3(13)	2	4.2	42
SP-312	9.3	304	60	61.3(6246)	132.8(13532)	0.6(6)	1.3(13)	2	6.4	52.8

### 外型尺寸 DIMENSIONS

Model	A(h7)	A1	B	C	D	E	F	G	H	J max.	J min.
SP-304	148	110	84	130	15	-	25.25	52	14	3.75	0.75
SP-306	206	168	94	188	15	25	40.25	73	20	10.75	4.75
SP-308	248	210	108	230	15	32	41.25	95	25	12.25	8.75
SP-310	300	254	112	280	16	54	46.25	110	30	23.25	12.75
SP-312	350	304	130	330	18	65	54	130	30	30.75	12.75

Model	K max.	K min.	L	M	N	P	Q	R	S	T
SP-304	31.5	28.95	23	10	M8x1.25	9	110.5	75.5	-	-
SP-306	47	44.25	31	12	M10x1.5	11	139.5	104.5	55	18
SP-308	57	53.6	35	14	M10x1.5	11	160.5	125.5	68	25
SP-310	64.5	61	40	16	M12x1.75	13	182.5	147.5	85	30
SP-312	77.5	72.85	50	21	M12x1.75	13	207.5	172.5	100	35

立置式夾頭